

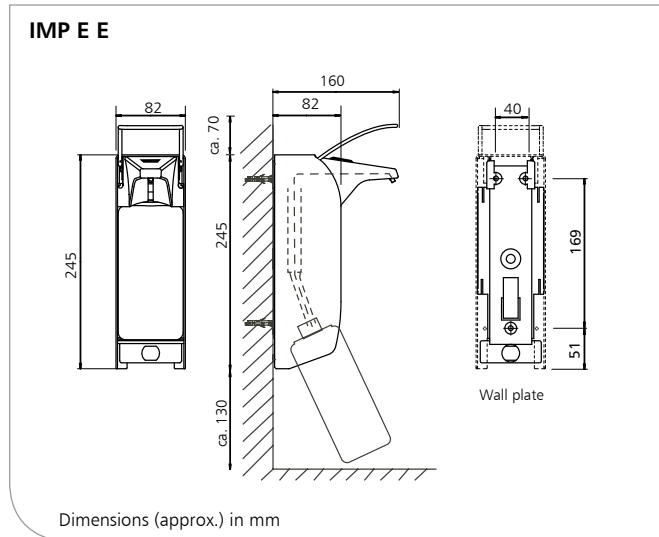

IMP E E - IMP T E

Soap-/disinfectant dispenser for disposable bottles as well as refillable containers and hygiene packages, stainless steel housing, short operating lever, 500 ml or 1000 ml



Product characteristics

- ▶ Dispenser for liquid soaps without grit, alcoholic hand disinfectants, lotion, massage oil, etc.
- ▶ For 500 ml or 1000 ml disposable bottles as well as refillable containers and hygiene packages
- ▶ With replaceable pump
- ▶ Pivoting face shield for simple pump replacement from the front without having to remove the dispenser from the wall
- ▶ Incl. mounting kit for three-point wall mounting

Interesting information

References:

- ▶ Clinics, doctors' practices, health and care facilities, laboratories, rescue stations, commercial kitchens, foodstuffs industry, commercial and industrial operations

Application examples:

- ▶ Particularly well suited to areas where hand hygiene is critical and in medical and food processing areas

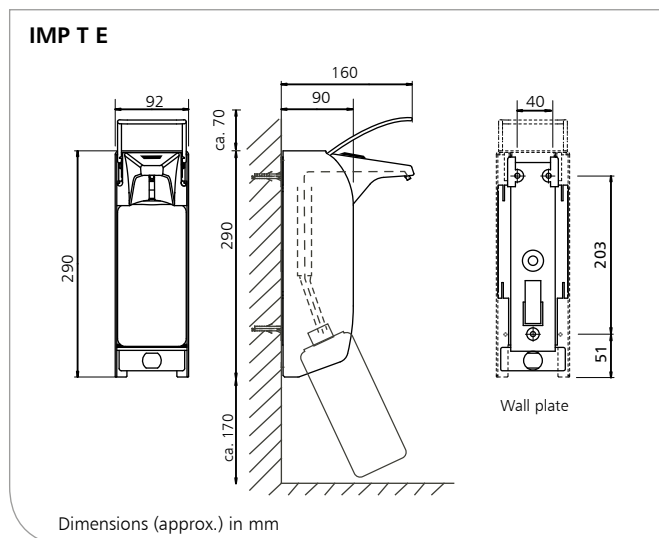

Technical data

Housing:

Stainless steel, brushed

Dosing pump:

IMP 24 series stainless steel pump, standard pump, angled stainless steel suction tube, autoclavable, stainless steel pump cylinder

Dispensing quantity:

Dispensing quantity adjustable to ca. 0.75 ml/1.0 ml/1.2 ml/1.5 ml (depending on the viscosity of the filling material)

Operating lever:

Stainless steel

Wall plate:

Standard ingo-man® plastic wall plate

Wall mounting:

Wall mounting with 3 screws and wall plugs

Cleaning:

Dispenser and standard pump dishwasher-safe and autoclavable up to 134° C, 2 bar

Description for tender - see overleaf

IMP E E - IMP T E/1216/1.0



Subject to technical modifications.
Tests are required before new filling materials are used!

OPHARDT
hygiene

OPHARDT Hygiene-Technik GmbH + Co. KG
Lindenau 27 | 47661 Issum | Germany
Tel.: +49 2835 18-10 | Fax: +49 2835 18-77
www.ophardt.com | E-Mail: planer@ophardt.com

IMP E E - IMP T E

Soap-/disinfectant dispenser for disposable bottles as well as refillable containers and hygiene packages, stainless steel housing, short operating lever, 500 ml or 1000 ml

Description for tender

... Pcs.	ingo-man® plus IMP E E/24 Art. No. 1417023 Soap-/disinfectant dispenser, 500 ml, suitable for standard disposable bottles, refillable containers and hygiene packages, brushed stainless steel housing, short stainless steel operating lever, with identification clip, incl. empty bottle, replaceable IMP 24 series stainless steel pump, easy pump replacement through front removal, autoclavable and dishwasher-safe Dimensions: W 82 x H 245 x D 160 mm	... Pcs.	ingo-man® plus IMP E E/K Art. No. 1417552 Soap-/disinfectant dispenser, 500 ml, suitable for standard disposable bottles, refillable containers and hygiene packages, brushed stainless steel housing, short stainless steel operating lever, with identification clip, incl. empty bottle, replaceable plastic pump, easy pump replacement through front removal, autoclavable and dishwasher-safe Dimensions: W 82 x H 245 x D 160 mm
... Pcs.	ingo-man® plus IMP T E/24 Art. No. 1417024 Soap-/disinfectant dispenser, 1000 ml, suitable for standard disposable bottles, refillable containers and hygiene packages, brushed stainless steel housing, short stainless steel operating lever, with identification clip, incl. empty bottle, replaceable IMP 24 series stainless steel pump, easy pump replacement through front removal, autoclavable and dishwasher-safe Dimensions: W 92 x H 290 x D 160 mm	... Pcs.	ingo-man® plus IMP T E/K Art. No. 1417592 Soap-/disinfectant dispenser, 1000 ml, suitable for standard disposable bottles, refillable containers and hygiene packages, brushed stainless steel housing, short stainless steel operating lever, with identification clip, incl. empty bottle, replaceable plastic pump, easy pump replacement through front removal, autoclavable and dishwasher-safe Dimensions: W 92 x H 290 x D 160 mm
... Pcs.	ingo-man® plus IMP E E/25 Art. No. 1417551 Soap-/disinfectant dispenser, 500 ml, suitable for standard disposable bottles, refillable containers and hygiene packages, brushed stainless steel housing, short stainless steel operating lever, with identification clip, incl. empty bottle, replaceable IMP 25 series stainless steel pump, easy pump replacement through front removal, autoclavable and dishwasher-safe Dimensions: W 82 x H 245 x D 160 mm	... Pcs.	ingo-man® plus IMP E E/KSP Art. No. 1417553 Soap-/disinfectant dispenser, 500 ml, suitable for standard disposable bottles, refillable containers and hygiene packages, brushed stainless steel housing, short stainless steel operating lever, with identification clip, incl. empty bottle, replaceable plastic spray pump, easy pump replacement through front removal, autoclavable and dishwasher-safe Dimensions: W 82 x H 245 x D 160 mm
... Pcs.	ingo-man® plus IMP T E/25 Art. No. 1417591 Soap-/disinfectant dispenser, 1000 ml, suitable for standard disposable bottles, refillable containers and hygiene packages, brushed stainless steel housing, short stainless steel operating lever, with identification clip, incl. empty bottle, replaceable IMP 25 series stainless steel pump, easy pump replacement through front removal, autoclavable and dishwasher-safe Dimensions: W 92 x H 290 x D 160 mm	... Pcs.	ingo-man® plus IMP T E/KSP Art. No. 1417593 Soap-/disinfectant dispenser, 1000 ml, suitable for standard disposable bottles, refillable containers and hygiene packages, brushed stainless steel housing, short stainless steel operating lever, with identification clip, incl. empty bottle, replaceable plastic spray pump, easy pump replacement through front removal, autoclavable and dishwasher-safe Dimensions: W 92 x H 290 x D 160 mm

Product:

Manufacturer:

ingo-man® plus

OPHARDT HYGIENE-TECHNIK GmbH + Co. KG