

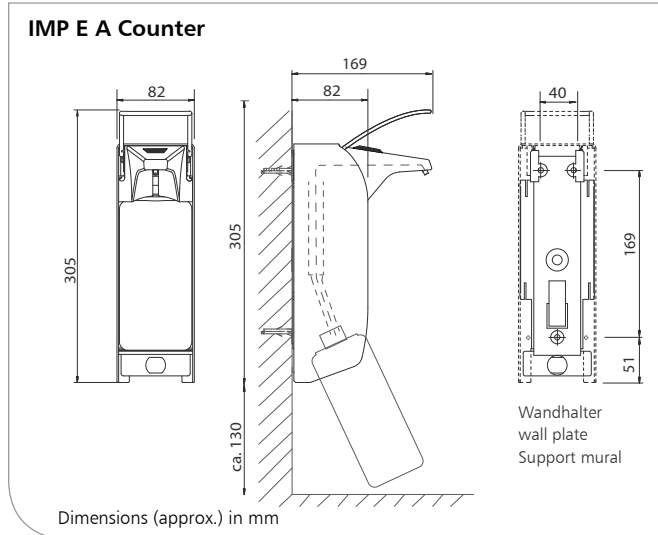

IMP E A Counter - IMP T A Counter

Soap-/disinfectant dispenser for disposable bottles as well as refillable containers and hygiene packages, aluminium housing, short operating lever, 500 ml or 1000 ml



Product characteristics

- ▶ Dispenser for liquid soaps without grit, alcoholic hand disinfectants, lotion, massage oil, etc.
- ▶ For 500 ml or 1000 ml disposable bottles as well as refillable containers and hygiene packages
- ▶ For different pump types
- ▶ Pivoting face shield for simple pump replacement from the front without having to remove the dispenser from the wall
- ▶ Incl. mounting kit for three-point wall mounting

Interesting information

References:

- ▶ Clinics, doctors' practices, health and care facilities, laboratories, rescue stations, commercial kitchens, foodstuffs industry, commercial and industrial operations

Application examples:

- ▶ Particularly well suited to areas where hand hygiene is critical and in medical and food processing areas

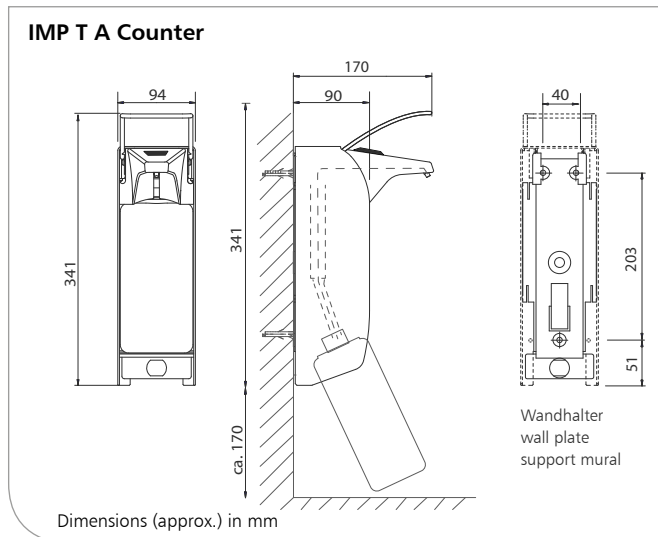

Technical data

Housing:

Aluminium, anodised matt silver

Dosing pump:

DHP disposable hygiene pump, made with recyclable plastic (standard pump, for other pumps see overleaf)

Dispensing quantity:

1.5 ml/stroke (depending on the viscosity of the filling material)

Operating lever:

Stainless steel

Wall plate:

Standard ingo-man® plastic wall plate

Wall mounting:

Wall mounting with 3 screws and wall plugs

Cleaning:

Dispenser dishwasher-safe and autoclavable up to 134° C, 2 bar, after removal of the counter and the standard pump

Description for tender - see overleaf

IMP E A Counter - IMP T A Counter 0420/2.2



Subject to technical modifications.
Tests are required before new filling materials are used!



OPHARDT HYGIENE-TECHNIK GmbH + Co. KG

Lindenau 27 | 47661 Issum | Germany

Tel.: +49 (0) 28 35 18-10 | Fax +49 (0) 28 35 18-77

planer@ophardt.com | www.ophardt.com

IMP E A Counter - IMP T A Counter

Soap-/disinfectant dispenser for disposable bottles as well as refillable containers and hygiene packages, aluminium housing, short operating lever, 500 ml or 1000 ml

Description for tender

... Pcs.	ingo-man® plus IMP E A/DHP Counter Art. No. 4402131 Soap-/disinfectant dispenser, 500 ml, suitable for standard disposable bottles, refillable containers and hygiene packages, matt silver anodised aluminium housing, short stainless steel operating lever, with digital counter for measuring dispenser use, with identification clip, dispenser autoclavable and dishwasher-safe after removal of the counter, recyclable disposable pump, plastic, easy pump replacement through front removal Dimensions: W 82 x H 305 x D 169 mm	... Pcs.	ingo-man® plus IMP E A/25 Counter Art. No. 1417566 Soap-/disinfectant dispenser, 500 ml, suitable for standard disposable bottles, refillable containers and hygiene packages, matt silver anodised aluminium housing, short stainless steel operating lever, with digital counter for measuring dispenser use, with identification clip, incl. empty bottle, replaceable IMP 25 series stainless steel pump, autoclavable and dishwasher-safe, pump can be quickly and simply removed for cleaning through front removal - can be put back into service in reverse order with "push and click" system, dispenser and pump autoclavable and dishwasher-safe after removal of the counter Dimensions: W 82 x H 305 x D 169 mm
... Pcs.	ingo-man® plus IMP T A/DHP Counter Art. No. 4402125 Soap-/disinfectant dispenser, 1000 ml, suitable for standard disposable bottles, refillable containers and hygiene packages, matt silver anodised aluminium housing, short stainless steel operating lever, with digital counter for measuring dispenser use, with identification clip, dispenser autoclavable and dishwasher-safe after removal of the counter, recyclable disposable pump, plastic, easy pump replacement through front removal Dimensions: W 94 x H 341 x D 170 mm	... Pcs.	ingo-man® plus IMP T A/25 Counter Art. No. 1417606 Soap-/disinfectant dispenser, 1000 ml, suitable for standard disposable bottles, refillable containers and hygiene packages, matt silver anodised aluminium housing, short stainless steel operating lever, with digital counter for measuring dispenser use, with identification clip, incl. empty bottle, replaceable IMP 25 series stainless steel pump, pump can be quickly and simply removed for cleaning through front removal - can be put back into service in reverse order with "push and click" system, dispenser and pump autoclavable and dishwasher-safe after removal of the counter Dimensions: W 94 x H 341 x D 170 mm
... Pcs.	ingo-man® plus IMP E A/24 Counter Art. No. 1417455 Soap-/disinfectant dispenser, 500 ml, suitable for standard disposable bottles, refillable containers and hygiene packages, matt silver anodised aluminium housing, short stainless steel operating lever, with digital counter for measuring dispenser use, with identification clip, incl. empty bottle, replaceable IMP 24 series stainless steel pump, pump can be quickly and simply removed for cleaning through front removal - can be put back into service in reverse order with "push and click" system, dispenser and pump autoclavable and dishwasher-safe after removal of the counter Dimensions: W 82 x H 305 x D 169 mm	... Pcs.	ingo-man® plus IMP E A/K Counter Art. No. 1417567 Soap-/disinfectant dispenser, 500 ml, suitable for standard disposable bottles, refillable containers and hygiene packages, matt silver anodised aluminium housing, short stainless steel operating lever, with digital counter for measuring dispenser use, with identification clip, incl. empty bottle, dishwasher-safe, replaceable plastic pump, pump can be quickly and simply removed for cleaning through front removal - can be put back into service in reverse order with "push and click" system, dispenser autoclavable and dishwasher-safe after removal of the counter Dimensions: W 82 x H 305 x D 169 mm
... Pcs.	ingo-man® plus IMP T A/24 Counter Art. No. 1417457 Soap-/disinfectant dispenser, 1000 ml, suitable for standard disposable bottles, refillable containers and hygiene packages, matt silver anodised aluminium housing, short stainless steel operating lever, with digital counter for measuring dispenser use, with identification clip, incl. empty bottle, replaceable IMP 24 series stainless steel pump, pump can be quickly and simply removed for cleaning through front removal - can be put back into service in reverse order with "push and click" system, dispenser and pump autoclavable and dishwasher-safe after removal of the counter Dimensions: W 94 x H 341 x D 170 mm		

IMP E A Counter - IMP T A Counter

Soap-/disinfectant dispenser for disposable bottles as well as refillable containers and hygiene packages, aluminium housing, short operating lever, 500 ml or 1000 ml

ingo-man® plus IMP T A/K Counter
Art. No. 1417607

. . . Pcs. Soap-/disinfectant dispenser, 1000 ml, suitable for standard disposable bottles, refillable containers and hygiene packages, matt silver anodised aluminium housing, short stainless steel operating lever, with digital counter for measuring dispenser use, with identification clip, incl. empty bottle, dishwasher-safe, replaceable plastic pump, pump can be quickly and simply removed for cleaning through front removal - can be put back into service in reverse order with "push and click" system, dispenser autoclavable and dishwasher-safe after removal of the counter
Dimensions: W 94 x H 341 x D 170 mm

ingo-man® plus IMP E A/KSP Counter
Art. No. 1417568

. . . Pcs. Soap-/disinfectant dispenser, 500 ml, suitable for standard disposable bottles, refillable containers and hygiene packages, matt silver anodised aluminium housing, short stainless steel operating lever, with digital counter for measuring dispenser use, with identification clip, incl. empty bottle, replaceable plastic spray pump, pump can be quickly and simply removed for cleaning through front removal - can be put back into service in reverse order with "push and click" system, dispenser autoclavable and dishwasher-safe after removal of the counter
Dimensions: W 82 x H 305 x D 169 mm

ingo-man® plus IMP T A/KSP Counter
Art. No. 1417608

. . . Pcs. Soap-/disinfectant dispenser, 1000 ml, suitable for standard disposable bottles, refillable containers and hygiene packages, matt silver anodised aluminium housing, short stainless steel operating lever, with digital counter for measuring dispenser use, with identification clip, incl. empty bottle, replaceable plastic spray pump, pump can be quickly and simply removed for cleaning through front removal - can be put back into service in reverse order with "push and click" system, dispenser autoclavable and dishwasher-safe after removal of the counter
Dimensions: W 94 x H 341 x D 170 mm

Product: **ingo-man® plus**
Manufacturer: OPHARDT HYGIENE-TECHNIK GmbH + Co. KG